

Design

The Hallite 51 is a heavy duty piston seal which, when installed in pairs, provides an excellent double acting piston design. It is particularly suitable for difficult operating conditions such as pressure surging, vibration or some misalignment.

The seal is an assembly of three parts, a male adaptor, a V ring and a female adaptor. Both the V ring and the female adaptor are made from rubberised fabric which has durability and strength, it also retains lubricant at the sliding surfaces so friction and wear are kept to a minimum. The V ring being the primary seal is more flexible than the adaptor which supports it and prevents extrusion damage. At higher pressures the adaptor deforms and becomes a secondary seal.

The polyacetal male adaptor has grooves across the face to ensure pressure is evenly applied to the V ring.

Features

- Effective seal for extreme applications
- Precision moulded vee packs
- High load capability
- Pressure activating grooves

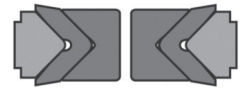
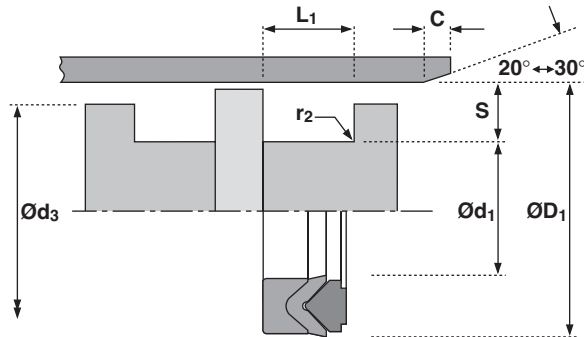

Technical details

Operating conditions

| | |
|-------------------|--------------|
| Maximum Speed | 0.5 m/sec |
| Temperature Range | -30°C +100°C |
| Maximum Pressure | 700 bar |

Inch

| | |
|-------------------|---------------|
| Maximum Speed | 1.5 ft/sec |
| Temperature Range | -22°F +212°F |
| Maximum Pressure | 10,000 p.s.i. |

Maximum extrusion gap

| | | | | |
|-----------------|------|------|------|-------|
| Pressure bar | 160 | 250 | 400 | 700 |
| Maximum Gap mm | 0.35 | 0.3 | 0.2 | 0.1 |
| Pressure p.s.i. | 2400 | 3750 | 6000 | 10000 |

Figures show the maximum permissible gap all on one side using minimum rod Ø and maximum clearance Ø.

Surface roughness

| | µmRa | µmRt | µinCLA | µinRMS |
|--------------------------------------|------------|--------|---------|---------|
| Dynamic Sealing Face ØD ₁ | 0.1 <> 0.4 | 4 max | 4 <> 16 | 5 <> 18 |
| Static Sealing Face Ød ₁ | 1.6 max | 10 max | 63 max | 70 max |
| Static Housing Faces L ₁ | 3.2 max | 16 max | 125 max | 140 max |

Chamfers & Radii

| | | | | |
|----------------------------------|-----|------|------|------|
| Groove Section ≤ S mm | 7.5 | 10.0 | 12.5 | 15.0 |
| Min Chamfer C mm | 4.0 | 5.0 | 6.5 | 7.5 |
| Max Fillet Rad r ₁ mm | 0.8 | 1.2 | 1.6 | 1.6 |

Tolerances

| | ØD ₁ | Ød ₁ | Ød ₃ | L ₁ |
|----|-----------------|-----------------|-----------------|----------------|
| mm | H9 | h11 | +0 -0.3 | +0.25 -0 |



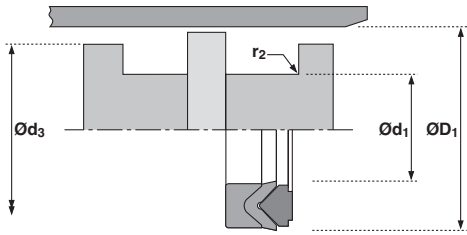

| ØD ₁ | TOL H9 | Ød ₁ | TOL h11 | Ød ₃ +0 -0.3 | L ₁ +0.25 -0 | PART No. |
|-----------------|----------------|-----------------|----------------|----------------------------|----------------------------|-------------|
| 30 | +0.05 +0.00 | 20 | +0.00 -0.13 | 29.0 | 9.30 | 4208310 |
| 40 | +0.06 +0.00 | 25 | +0.00 -0.13 | 39.0 | 11.50 | 4208010 |
| 50 | +0.06 +0.00 | 35 | +0.00 -0.16 | 49.0 | 11.50 | 4207610 |
| 55 | +0.07 +0.00 | 40 | +0.00 -0.16 | 54.0 | 11.50 | 4207110 |
| 60 | +0.07 +0.00 | 45 | +0.00 -0.16 | 59.0 | 11.50 | 4207210 |
| 63 | +0.07 +0.00 | 48 | +0.00 -0.16 | 62.0 | 13.00 | 4207410 |
| 70 | +0.07 +0.00 | 50 | +0.00 -0.16 | 68.5 | 15.20 | 4208210 |
| 80 | +0.07 +0.00 | 60 | +0.00 -0.19 | 78.5 | 15.20 | 4208110 |
| 90 | +0.09 +0.00 | 70 | +0.00 -0.19 | 88.5 | 21.20 | 4207710 |
| 100 | +0.09 +0.00 | 80 | +0.00 -0.19 | 98.5 | 21.20 | 4207510 |
| 110 | +0.09 +0.00 | 90 | +0.00 -0.22 | 108.5 | 21.20 | 4207910 |

| ØD ₁ | TOL H9 | Ød ₁ | TOL h11 | Ød ₃ +0 -0.3 | L ₁ +0.25 -0 | PART No. |
|-----------------|----------------|-----------------|----------------|----------------------------|----------------------------|-------------|
| 125 | +0.10 +0.00 | 100 | +0.00 -0.22 | 123.5 | 25.80 | 4207810 |
| 140 | +0.10 +0.00 | 115 | +0.00 -0.22 | 138.5 | 25.80 | 4208410 |
| 150 | +0.10 +0.00 | 120 | +0.00 -0.22 | 148.0 | 29.00 | 4208510 |
| 160 | +0.10 +0.00 | 130 | +0.00 -0.25 | 158.0 | 29.00 | 4208710 |
| 180 | +0.10 +0.00 | 150 | +0.00 -0.25 | 178.0 | 31.50 | 4208610 |
| 200 | +0.12 +0.00 | 170 | +0.00 -0.25 | 198.0 | 33.50 | 4209010 |
| 225 | +0.12 +0.00 | 195 | +0.00 -0.29 | 223.0 | 33.50 | 6582110 |
| 250 | +0.12 +0.00 | 220 | +0.00 -0.29 | 248.0 | 33.50 | 6582310 |
| 275 | +0.13 +0.00 | 245 | +0.00 -0.29 | 273.0 | 33.50 | 6582410 |
| 300 | +0.13 +0.00 | 270 | +0.00 -0.32 | 298.0 | 33.50 | 6582510 |
| 320 | +0.14 +0.00 | 290 | +0.00 -0.36 | 318.0 | 33.50 | 6582610 |

Seal & Design Able Division

5533 Steeles Avenue West Unit 11
Toronto, Ontario M9L 1S7
Ph: (416) 741-0750
Gasket@AbleSealAndDesign.com

Seal & Design Corporate Headquarters

4015 Casilio Parkway
Clarence, NY 14031
Ph: (716) 759-2222
Info@SealAndDesign.com
www.SealAndDesign.com

Seal & Design Higbee Division

6741 Thompson Rd N
Syracuse, NY 13221
Ph: (315) 432-8021
Sales@Higbee-Inc.com